

大林様

10-5 Supply of oil

Lubrication is an indispensable factor for executing harmonious operation of the machine maintaining its accuracy. In particular, as lubrication has a very important role for the machine which aims at unmanned operation, keep it always in your mind to enable proper lubrication and utmost care.

10-5-1 Lubrication oil list

Use the lubrication oil shown below.

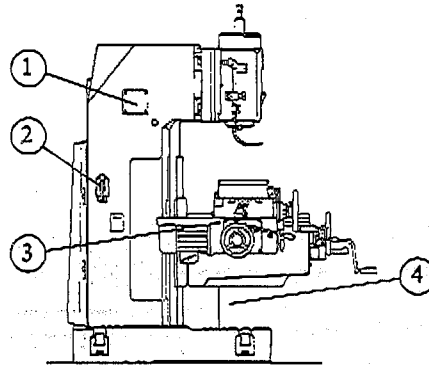

		LUBRICATION SPOTS			
		① Main spindle gear box	② Feed slideway (Lubrication system)	③ Feed gear box	④ Knee vertical screw / nut
Oil supply	Interval for oil supply	6 months	At voluntary time	6 months	Every week
	Oil supply rate	10 L (0.26gal)	350cc (0.09gal)	1.5 L (0.4gal)	Suitable amount
	Oil supply method	Exchange	Replenishment	Exchange	Replenishment
Recommendation Brands	Idemitsu Kosan	Daphne super multi oil 10	Daphne multiway oil 68ER	Daphne super multi oil 68	Daphne sponex grease No.0
	Showa Shell	Shell Tetra oil 10	Shell Tonna oil S68	Shell Tetra oil 68	Shell Sunlight grease 0
	Mobil Oil	Mobil velocity oil No.6	Mobil vactra oil No.2	Mobil DTE oil heavy medium	Mobil Mobilax EP0
	Nippon Oil	Super malpus 10	Uniway SF68,HP68	Super malpus 68	Multinoc grease 1
	Castrol Oil	Magna 10	Magna BD 68	Hyspin AW 68	Sheerol AP2



NOTE

Lubricant distributed by Idemitsui have been applied when the machine was shipped. In case of using the oil distributed of other makers of the above, the oil remaining in the tank and in the spindle must be replaced. Mixing with the other types of oil may cause chemical reactions, resulting in the deterioration of oil.

大林